



OWNERS MANUAL

fluid 29
130

A DIVISION OF



MOUNTAIN RACING PRODUCTS, INC
580 N. WESTGATE DR.
GRAND JUNCTION, CO 81505 USA
1.970.241.3518
WWW.WHITEBROTHERSCYCLING.COM

TABLE OF CONTENTS

SAFETY.....	PAGE 2
INTRODUCTION.....	PAGE 2
FORK INSTALLATION.....	PAGE 3
TUNING.....	PAGE 4
MAINTENANCE.....	PAGE 5
TROUBLE SHOOTING.....	PAGE 6
WARRANTY.....	PAGE 7

IMPORTANT CONSUMER SAFETY INFORMATION

WARNING: RIDING A BIKE IS DANGEROUS. NOT PROPERLY MAINTAINING OR INSPECTING YOUR BIKE AND IT'S COMPONENTS IS EVEN MORE DANGEROUS. IT IS ALSO DANGEROUS TO NOT READ AND FOLLOW THESE INSTRUCTIONS.

1. NEVER REMOVE STEERER TUBE FROM CROWN. THIS IS A PRESSED IN PART. REMOVING IT WILL RENDER BOTH THE CROWN AND STEERER TUBE INOPERABLE.* MAKE SURE THE FORK CAPS AND ALL FORK HARDWARE (pinch bolts, etc.) ARE TIGHT BEFORE EACH RIDE.
2. DO NOT PERFORM ANY MODIFICATIONS OR ADJUSTMENTS THAT ARE NOT OUTLINED IN THIS MANUAL. SEE THE TUNING SECTION FOR MORE DETAILS.
3. INSPECT YOUR FORK BEFORE EVERY RIDE. INSPECT THE CROWN, TUBES, AND AXLE SEAT AREAS FOR ANY SIGNS OF FATIGUE, BENDING, CRACKING OR OTHER DAMAGE. IF YOU NOTICE ANY TYPE OF DAMAGE, DO NOT RIDE IT. RETURN IT TO YOUR DEALER OR TO WHITE BROTHERS FOR A COMPLETE INSPECTION AND NECESSARY REPAIR.
4. THIS WHITE BROTHERS FORK IS DESIGNED WITH A LOCKOUT THAT TURNS OFF THE FORK'S SUSPENSION. THE LOCKOUT IS ONLY DESIGNED TO BE USED ON SMOOTH TERRAIN. USING THE LOCKOUT ON ROUGH TERRAIN, BUMPS OR DROP-OFFS CAN CAUSE SERIOUS DAMAGE TO THE FORK AND COULD CAUSE SERIOUS PERSONAL INJURY OR DEATH.
5. PERFORM ALL RECOMMENDED MAINTENANCE ACCORDING TO THE MAINTENANCE SECTION OF THIS MANUAL. FAILURE TO PERFORM MAINTENANCE COULD DRASTICALLY REDUCE THE FORK'S LIFE, PERFORMANCE AND CAUSE YOUR FORK TO BE A SAFETY HAZARD.
6. WHITE BROTHERS RECOMMENDS THAT YOU WEAR PROPER SAFETY EQUIPMENT EVERY TIME YOU RIDE, INCLUDING AN APPROVED BICYCLE HELMET. NEVER RIDE AT NIGHT WITHOUT LIGHTS.
7. ALWAYS USE GENUINE WHITE BROTHERS PARTS. USE OF AFTERMARKET REPLACEMENT PARTS AND UPGRADES VOIDS THE WARRANTY AND COULD CAUSE STRUCTURAL FAILURE.
8. WHITE BROTHERS FORKS ARE DESIGNED FOR OFF ROAD USE ONLY. THEY ARE NOT EQUIPPED WITH REFLECTORS FOR ROAD USE. IF YOU

ARE GOING TO USE YOUR FORK ON THE ROAD, HAVE A DEALER OR MECHANIC INSTALL REFLECTORS THAT MEET THE CONSUMER PRODUCT SAFETY COMMISSION'S REQUIREMENTS.

9. ALL WHITE BROTHERS 20MM FORKS ARE DESIGNED BASED ON THE IS DISK BRAKE STANDARD. IF YOUR WHITE BROTHERS FORK HAS A 20MM THROUGH AXLE, IT IS CRITICAL TO SAFETY AND FUNCTION THAT YOU ONLY USE A DISK BRAKE PROPERLY DESIGNED FOR THE 20MM IS DISK BRAKE STANDARD. SIMPLY SPACING A NON 20MM DISK BRAKE TO WORK ON THE 20MM FORK MAY RESULT IN INSUFFICIENT THREAD ENGAGEMENT WHEN ATTACHING THE BRAKE. THIS CAN RESULT IN SERIOUS BODILY INJURY OR DEATH. ONLY USE DISK BRAKES PROPERLY DESIGNED FOR THE 20MM IS DISK BRAKE STANDARD.

**IF SERVICE BECOMES NECESSARY OR REMOVAL OCCURS, PLEASE CALL WHITE BROTHERS CUSTOMER SERVICE FOR PRODUCT EVALUATION AND DIAGNOSIS.*

INTRODUCTION

Thank you for purchasing your new White Brothers fork. Our forks are designed to help you perform at your absolute peak. Your new White Brothers fork has oil damping and is air sprung for light weight performance. The air spring and damper is set stock to satisfy a wide range of rider weights and riding styles. Fine tuning can be easily accomplished by changing air pressure of the air spring. See the adjustment and maintenance section for rider weight verses air pressures settings. For very heavy or very light riders the external damper can be adjusted to give a wide range of compression and rebound damping. Steering accuracy is improved over conventional MTB forks by utilizing superior materials and design. These include oversized 32mm fork tubes, a torsion box design steering crown with pressed in tubes, a one piece billet brake arch and extra thick drop-outs. The WB forks bootless design allows a considerable amount more slider/stanchion overlap than competitor forks which increases the fork steering accuracy. Fork travel has been chosen to offer the best performance possible for each fork's intended use. To ensure peak performance, proper installation and periodic maintenance is required. When riding on public land, please respect the rights of others and stay on established paths and trails. By riding responsibly, you are helping ensure the future of our sport.

FORK INSTALLATION

White Brothers forks feature a 1-1/8" threadless steer tube. If you have a threaded type fork on your bicycle, consult your dealer for the appropriate upgrade parts necessary to convert to a 1-1/8" threadless steer tube.

1. Remove your old fork from the bicycle. Measure the diameter and length of your old forks steerer tube to ensure that the White Brothers steerer tube is the correct diameter and sufficient length for the installation.
2. Remove the crown race from your old fork.
3. Press the crown race onto your new White Brothers fork. **(see Figure #1)**
4. Preassemble the headset by sliding the fork steerer tube through the bearings. Then install the headset upper race, headset spacer (optional), and stem onto the fork steerer tube. Adjust with optional spacers to your preferred height. **(See Figure #2)** Refer to the head set owner's manual if there are any questions about the pre-assembly.
5. Mark the steerer tube at the top of the stem. The steerer tube will now need to be cut to the correct length. Disassemble and cut 3mm (1/8") below the mark. Consult your dealer or

mechanic if you don't have the proper tools to cut the steer tube.

6. The star fangled nut must now be installed into the steer tube. If you don't have the set tool, we recommend dealer installation of this part. **(See Figure #3)**
7. Clean and grease all headset bearings and races to prepare them for assembly. *Note: Replace the bearings if there is any sign of wear or corrosion.*
8. Now loosely assemble the headset, stem and handle bars as done in step four.
9. Install the headset top cap into the star fangled nut. Tighten until there is no play in the steering. The fork should rotate freely in the head tube. Straighten the stem in relation to the front tire and tighten the pinch bolts on the stem. If there are any questions consult your dealer or mechanic.
10. Install your front brake and adjust according to the manufacture's instructions.
11. Adjust the quick release on the hub to clear the secondary catches on the drop-outs. Tighten the quick release after the axle is properly seated in the drop-out. Ensure that there is sufficient thread engagement (5 or more threads with the quick release in the lock position) due to the thicker White Brothers drop-outs. Install the front wheel per manufactures specifications.
12. Check to see that the brakes are adjusted and properly working. Make sure that the brake cable does not interfere with any part of the bike when the fork is compressed and released.

WARNING: All White Brothers 20mm forks are designed based on the IS disk brake standard. If your White Brothers fork has a 20mm through axle, it is critical to safety and function that you only use a disk brake properly designed for the 20mm IS disk brake standard. Simply spacing a non 20mm disk brake to work on the 20mm fork may result in insufficient thread engagement when attaching the brake. This can result in SERIOUS BODILY INJURY OR DEATH. ONLY USE DISK BRAKES PROPERLY DESIGNED FOR THE 20MM IS DISK BRAKE STANDARD.

WARNING: When installing the wheel or a new tire, check for minimum clearance. Measure from the highest point on the tire to the under side of the crown. There must be 1/8" or 3mm more clearance than the fork's travel to ensure adequate clearance in all riding conditions. Any less clearance can result in the tire hitting the crown resulting in serious injury or death.

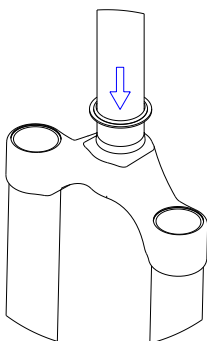

Figure #1

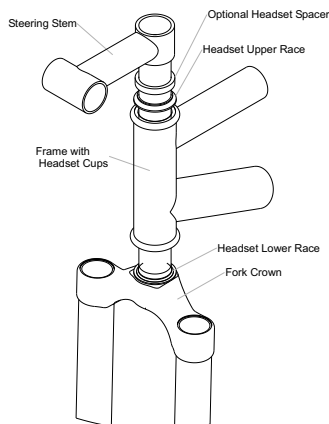

Figure #2

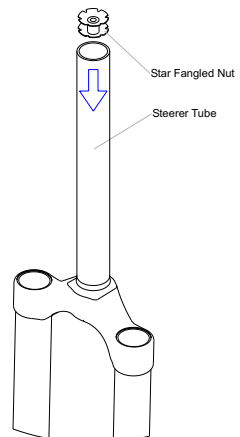

Figure #3

TUNING

To get the most out of your White Brothers fork, it is important that you tune the fork to fit your weight, riding style and the terrain you ride.

INITIAL BREAK-IN PERIOD:

Your new fork is designed to break-in over a period of 10 hours or more of riding. As all the parts bed into each other, the stiction (friction) of the fork decreases and the sensitivity increases. After the initial brake-in period, fine tuning the air pressure and damping adjustments may be beneficial to achieve the best possible performance.

TOOLS NEEDED:

- 24MM.socket with ratchet.
- 4mm Allen wrench
- 6mm Allen wrench

AIR SPRING / OIL DAMPER

Your new White Brothers fork is designed with a air spring and oil damping. The following guidelines for adjusting and maintaining your fork will enable you to enjoy maximum performance and longevity from your fork.

1. First, test ride the fork over easy terrain. If after riding the fork over varied terrain you decide that more tuning is necessary, continue to the next step.
2. The compression or spring of the fork can be changed two ways: 1) by adjusting the spring air pressure 2)by adjusting the rebound setting or adding air to the damper.
3. To adjust the air pressure remove the dust cap from the left leg to expose the air valve. Add or remove pressure using a high pressure air pump to achieve your desired spring support. 50-100psi. is the user range. The fork is delivered with 80 psi.
4. **Compression adjustment** is done by adding or removing air at the top of the right leg. Pressures can range from 50 to 150 lbs. Higher air pressure will provide more compression damping while lower air pressure will provide less compression damping. Less compression damping will increase the fork dive but will feel smoother over small bumps. More compression damping will feel stiffer over small bumps but will be more resistant to bottoming. **DO NOT COMPRESS FORK WITHOUT AIR IN DAMPER!**
5. **Rebound adjustment** is done by turning the knob on the bottom of the right leg. Turn the knob clockwise for slower rebound. To speed up rebound, turn the knob counter-clockwise. Start with a middle setting and fine tune the rebound from there. Proper rebound will allow the tire to track the ground over consecutive bumps. Too slow of rebound will pack-up (feel stiff over consecutive bumps) while rebound set too fast will cause the fork to top out harshly. Usable adjustment range is 1.5 to 6 turns out from bottom.

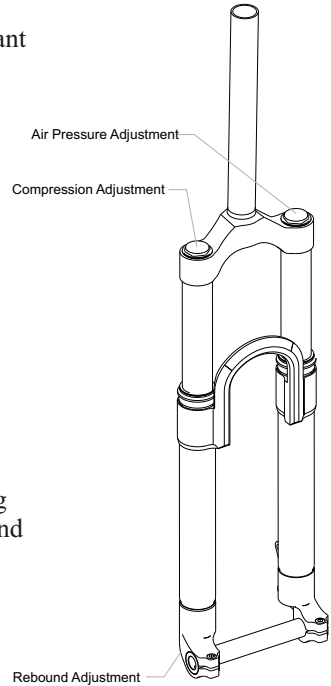

Figure #4

MAINTENANCE

Your White Brothers fork requires periodic maintenance to ensure peak performance and long life. Neglecting proper maintenance will reduce the fork's life. Internal build up of water and dirt or a lack of lubrication will cause excessive wear and void the warranty.

BEFORE EVERY RIDE: Visually inspect your fork for bent or broken parts, loss of oil, abnormal sounds or other indications of possible fork failure. Compress you fork to verify proper function. Check all other bicycle components to ensure proper working order.

AFTER EVERY RIDE: Clean and dry the exterior of your fork. When cleaning the fork, do not direct the water spray at the seals. Visually inspect your fork for damage.

***EVERY 30 HOURS OF RIDING:** Your fork should be disassembled, inspect, cleaned and re-grease. If the fork appears to be relatively clean, you can go 40 hours between servicing. If the fork appears excessively dirty you should service it every 20 hours. The three things that will effect the service interval and performance of your fork are water, mud and dust. How much you use your fork in those conditions will determine how much service it requires.

***EVERY 100 HOURS OF RIDING:** Complete service should include removing the lower fork legs cleaning and re-greasing all shafts, bushings and seals. Check top cap assembly's, damper cartridge, stanchion plug, brake bolts and shaft bolts for proper torque. At this time, the fork should be carefully inspected for wear and damage before reassembly. Contact White Brothers for replacement parts and service. We recommend that this service be performed by a certified White Brothers service center or by the factory.

*White Brothers recommends that you consult with a qualified technician before performing:

Basic Fork Disassembly and Inspection

1. Disconnect the front brake and remove the wheel as outlined in you bicycle owners manual.
2. **Remove the rebound** knob from the bottom of the right dropout. Loosen the allen bolts at the bottom of the fork legs(See figure #5). **Back out the compression screws 1/4" and using a dead blow hammer knock the bolts back into the lower legs.** Finish removing the compression screws.
3. Simply slide the fork legs off the end of the inner stanchion tubes.
4. Check the air pressure in the damper. It should be between 50 and 150 psi. Inspect the damper leg for visible leakage. Push in the damper rod to full compression. The damper rod should return on it's own. If the damper has visible leakage and/or the damping feels inconsistent as it is stroked, return the fork to White Brothers or a dealer familiar with rebuilding the damper for service. The damper is a sealed unit and should not be opened unless service is required. Damper service should be performed by White Brothers.
5. Remove the air pressure from the spring side air cap. Remove the top cap and check oil on the piston. It should have 10cc's of fork oil on the top of the piston. Install air cap

and inflate to desired pressure.

6. Clean all parts with a clean, non-abrasive rag. A mild grease cutting cleaner or solvent might make this an easier task. Once clean, inspect the seals for tears or cracks. If in good condition, re-grease them with Slick Honey or other suitable non-lithium grease. If your seals show signs of wear have them replaced.
7. Check the DU bushings carefully for wear. This is done by looking at the color of the bushings. If the bushings are dark gray, they are in good condition. If they are bronze/gold in areas, they are worn and can cause fork stanchion damage. If there is noticeable movement back and forth when the legs are fully engaged on the fork stanchions, the DU bushings may need to be replaced. Please note that special tools are required to remove and replace these bushings. This service can be performed by White Brothers.
8. Next, inspect the fork stanchion tubes for wear, nicks or scrapes. These will cause premature wear on the seals and DU bushings. Check again for noticeable play between the stanchion tubes and the fork lower.
9. If everything is free of problems, coat all parts with a liberal coat of Slick Honey or other non-lithium grease. Be sure to lube the DU bushings located inside the lower leg.

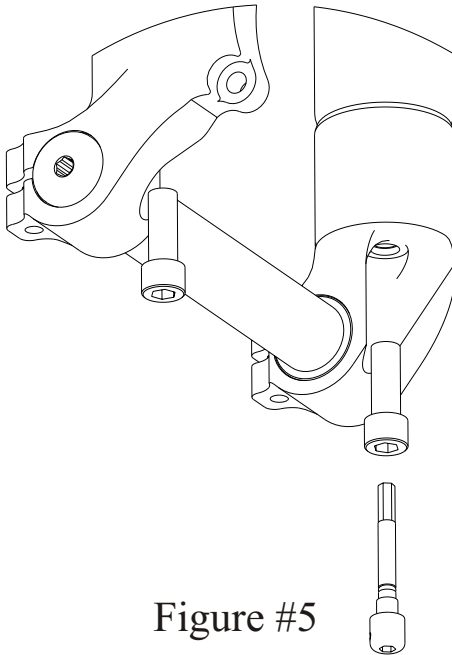

Figure #5

Basic Fork Reassembly

1. Make sure all the spacers and bottoming bumpers are installed on the control rods (see exploded views for proper installation). With all parts cleaned and reinstalled with new grease, fit the lower assembly over the stanchion tubes and gently rock and slide together until the control rods are touching the bottom of the lower assembly. Thread the compression screws into the control rods starting with the damper side and firmly tighten.. Downward pressure on the fork will help hold the control rods from rotating until the compression screws become tight. **Note: Ensure the compression screws are fully tight before riding.**
2. Check the spring air pressure 50-150 psi. Damper pressure should be between 50 and 150 psi.
3. Make sure the fork caps are fully tightened into the top of the stanchion tubes. Connect the front brake and wheel as outlined in you bicycle owners manual. Ensure that the 20mm axle nut and pinch clamps are tight before riding.
4. Compress the fork to make sure it works smoothly and the brake cable does not interfere with the operation of the fork.

TRUBLE SHOOTING

Fork Feels Sticky

This is usually caused by:

1. A lack of lubrication. Clean and lubricate the fork as outlined in the maintenance section.
2. Contamination inside the fork. Clean and lubricate the fork as outlined in the maintenance section.
3. Fork is not sufficiently broken in. Contact White Brothers for further technical information.

The Fork Bottoms Too Easily

1. Incorrect spring air pressure. Add air pressure as outlined in #3 of the tuning section.
2. Insufficient compression damping. Add compression damping by adding air (50-150 lb range) to the top of the right leg.

The Fork Doesn't Use Full Travel

1. Incorrect spring air pressure. Remove air pressure as outlined in #3 of the tuning section.
2. Excessive compression damping. Reduce the compression damping by removing air (50-150 lb range) from the top of the right leg.

Damping Adjustment is Not Working

1. Damper may need servicing. Contact White Brothers for technical information.

fluid 29

130

Exploded Views

The following is an illustration and parts table which gives you the exploded view of your White Brothers fork. The parts table indicates the part numbers for each individual part in the fork. Reference these numbers when ordering replacement parts. See your local dealer or contact White Brothers to order the parts you require.

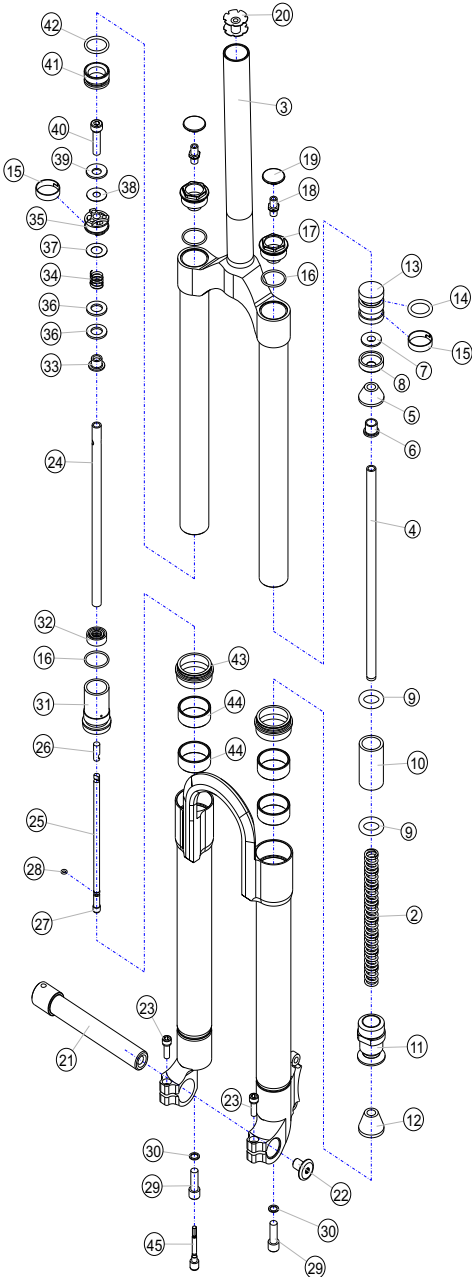

ITEM NO	QTY	PART NO.	DESCRIPTION
1	1	100225-20	Lower Assembly
	1	P1610-2	Brace disk only
2	100225		BW Outer Leg
	1	100532	20mm Dropout Damper Side
	1	100533	20mm Dropout Disk Side
2	8	100016	XC Negative Spring
3	1	P1139-1	Upper Assembly
	1	P1252	Steer Stem Single Crown
	1	97-3706-1	Crown
	2	97-3204	Inner Leg
4	1	Control Rod	Control Rod
5	1	97-3342	Topout Bumper
6	1	100576	Topout Bumper Guide
7	1	P4600	Compression Rod Top
8	1	P2504	Nylon Rod Bushing
9	2	F-2402	O-Ring 313
10	1	100577	Topout Spacer
11	1	Stan Plug	Stanchion Plug
12	1	P3290	Orange Compression Bumper
13	1	100572	Air Piston
14	1	100262	O-Ring 211
15	2	P3000	Piston Band
16	3	P3028	O-Ring 021
17	2	100060	Air Cap
18	2	100054	Schrader Valve Assm.
	1	100053	Schrader Valve
	1	100033	O-Ring 010
19	2	P4650	Dust Cap
20	1	97-9301	Star Nut
21	1	100285	20mm Axle
22	1	100531	20mm Axle Nut
23	2	97-852	Bolt M6
24	1	100049	FR Damper Shaft
25	1	100065	Rebound Adj Extension
26	1	100050	Rebound Adj Needle
27	1	100064	Hex Rebound Adj
28	1	ZTA-ORING-006	O-Ring 006
29	2	100063S	Compression Screw Solid
30	2	100055	Washer .3125 x .4375
31	1	P2201-1	Seal Head
32	1	97-1409	Shaft Seal
33	1	P2014	Check Valve Guide
34	1	P2015	Check Valve Spring
35	1	P2012	DH Piston
36	2	P3315-1	Pre-Load Spacer
37	1	P2004	Shim 23 x 12 x .25
38	1	P2006	Low Speed Shim 22 x 8 x .02
39	1	P2005	Belleville Washer
40	1	P4010	Damper Bolt
41	1	P2010	Floating Piston
42	1	P3021	O-Ring 118
43	2	97-1351	Wiper Seal
	1	97-1351	Wiper Seal
44	4	97-986	DU Bushing
45	1	100200	Damper Adjuster
	1	100052	Adjuster Knob
	1	100032	O-Ring 003

OWNERS NAME:

ADDRESS:

PHONE:

PURCHASE DATE:

PURCHASE LOCATION:

MAINTENANCE LOG

Date

Service Performed

<u>Date</u>	<u>Service Performed</u>

WARRANTY CLAIMS

White Brothers forks are the highest quality and as such are warranted to be free from defects in materials and workmanship for a period of one year from the date of purchase for the original purchaser. On receipt of the fork, if it is found to be defective, White Brothers will determine replacement or repair of the fork. This warranty is the sole and exclusive remedy. White Brothers shall not be liable for any indirect, special or consequential damages. Warranty does not apply to any product that has been installed improperly or adjusted using methods not outlined in this manual. Warranty also does not cover forks that have been misused, or forks that have missing/altered serial numbers (located on the back of the right fork stanchion). The fork is not warranted against damage in the appearance of the fork or for modifications not outlined in this manual. This warranty does not cover breakage, bending, or damage that may result from crashes, falls or abuse. Normal wear (i.e. seals, bushings, sliders finish, etc) and tear and damage caused by lack of proper maintenance is not included. ***The warranty registration card must be filled out and returned within 30 days of purchase to activate and validate this warranty.** A copy of the proof of purchase must be included with all warranties. Customers in the US please contact your White Brothers or your dealer for a Return Authorization Number (RA#) before returning the forks. All forks returned for inspection must be sent freight paid to:

White Brothers Cycling
580 N. Westgate Dr.
Grand Junction, CO 81505
USA



A DIVISION OF



MOUNTAIN RACING PRODUCTS, INC
580 N. WESTGATE DR.
GRAND JUNCTION, CO 81505 USA
1.970.241.3518
WWW.WHITEBROTHERSCYCLING.COM