



OWNERS MANUAL

magic
80

magic
100

magic 29
80

magic 29
100

A DIVISION OF



MOUNTAIN RACING PRODUCTS, INC
580 N. WESTGATE DR.
GRAND JUNCTION, CO 81505 USA
1.970.241.3518
WWW.WHITEBROTHERSCYCLING.COM

TABLE OF CONTENTS

SAFETY.....	PAGE 2
INTRODUCTION.....	PAGE 3
FORK INSTALLATION.....	PAGE 3
TUNING.....	PAGE 5
MAINTENANCE.....	PAGE 6
TROUBLE SHOOTING.....	PAGE 8
EXPLODED VIEWS.....	PAGES 9-12
WARRANTY.....	PAGE 13

IMPORTANT **CONSUMER SAFETY INFORMATION**

WARNING: RIDING A BIKE IS DANGEROUS. NOT PROPERLY MAINTAINING OR INSPECTING YOUR BIKE AND IT'S COMPONENTS IS EVEN MORE DANGEROUS. IT IS ALSO DANGEROUS TO NOT READ AND FOLLOW THESE INSTRUCTIONS.

1. NEVER REMOVE STEERER TUBE FROM CROWN. THIS IS A PRESSED IN PART. REMOVING IT WILL RENDER BOTH THE CROWN AND STEERER TUBE INOPERABLE. * MAKE SURE THE FORK CAPS AND ALL FORK HARDWARE (pinch bolts, etc.) ARE TIGHT BEFORE EACH RIDE.
2. DO NOT PERFORM ANY MODIFICATIONS OR ADJUSTMENTS THAT ARE NOT OUTLINED IN THIS MANUAL. SEE THE TUNING SECTION FOR MORE DETAILS.
3. INSPECT YOUR FORK BEFORE EVERY RIDE. INSPECT THE CROWN, TUBES, AND AXLE SEAT AREAS FOR ANY SIGNS OF FATIGUE, BENDING, CRACKING OR OTHER DAMAGE. IF YOU NOTICE ANY TYPE OF DAMAGE, DO NOT RIDE IT. RETURN IT TO YOUR DEALER OR TO WHITE BROTHERS FOR A COMPLETE INSPECTION AND NECESSARY REPAIR.
4. THIS WHITE BROTHERS FORK IS DESIGNED WITH A LOCKOUT THAT TURNS OFF THE FORK'S SUSPENSION. THE LOCKOUT IS ONLY DESIGNED TO BE USED ON SMOOTH TERRAIN. USING THE LOCKOUT ON ROUGH TERRAIN, BUMPS OR DROP-OFFS CAN CAUSE SERIOUS DAMAGE TO THE FORK AND COULD CAUSE SERIOUS PERSONAL INJURY OR DEATH.
5. PERFORM ALL RECOMMENDED MAINTENANCE ACCORDING TO THE MAINTENANCE SECTION OF THIS MANUAL. FAILURE TO PERFORM MAINTENANCE COULD DRASTICALLY REDUCE THE FORK'S LIFE, PERFORMANCE AND CAUSE YOUR FORK TO BE A SAFETY HAZARD.
6. WHITE BROTHERS RECOMMENDS THAT YOU WEAR PROPER SAFETY EQUIPMENT EVERY TIME YOU RIDE, INCLUDING AN APPROVED BICYCLE HELMET. NEVER RIDE AT NIGHT WITHOUT LIGHTS.
7. ALWAYS USE GENUINE WHITE BROTHERS PARTS. USE OF

AFTERMARKET REPLACEMENT PARTS AND UPGRADES VOIDS THE WARRANTY AND COULD CAUSE STRUCTURAL FAILURE.

8. WHITE BROTHERS FORKS ARE DESIGNED FOR OFF ROAD USE ONLY. THEY ARE NOT EQUIPPED WITH REFLECTORS FOR ROAD USE. IF YOU ARE GOING TO USE YOUR FORK ON THE ROAD, HAVE A DEALER OR MECHANIC INSTALL REFLECTORS THAT MEET THE CONSUMER PRODUCT SAFETY COMMISSION'S REQUIREMENTS.
9. ALL WHITE BROTHERS 20MM FORKS ARE DESIGNED BASED ON THE IS DISK BRAKE STANDARD. IF YOUR WHITE BROTHERS FORK HAS A 20MM THROUGH AXLE, IT IS CRITICAL TO SAFETY AND FUNCTION THAT YOU ONLY USE A DISK BRAKE PROPERLY DESIGNED FOR THE 20MM IS DISK BRAKE STANDARD. SIMPLY SPACING A NON 20MM DISK BRAKE TO WORK ON THE 20MM FORK MAY RESULT IN INSUFFICIENT THREAD ENGAGEMENT WHEN ATTACHING THE BRAKE. THIS CAN RESULT IN SERIOUS BODILY INJURY OR DEATH. ONLY USE DISK BRAKES PROPERLY DESIGNED FOR THE 20MM IS DISK BRAKE STANDARD.

**IF SERVICE BECOMES NECESSARY OR REMOVAL OCCURS, PLEASE CALL WHITE BROTHERS CUSTOMER SERVICE FOR PRODUCT EVALUATION AND DIAGNOSIS.*

INTRODUCTION

Thank you for purchasing your new White Brothers fork. Our forks are designed to help you perform at your absolute peak. Your new White Brothers fork has oil damping and is air sprung for light weight performance. The air spring and damper is set stock to satisfy a wide range of rider weights and riding styles. Fine tuning can be easily accomplished by changing air pressure of the air spring. See the adjustment and maintenance section for rider weight verses air pressures settings. For very heavy or very light riders the external damper can be adjusted to give a wide range of compression and rebound damping. Steering accuracy is improved over conventional MTB forks by utilizing superior materials and design. These include oversized 32mm fork tubes, a torsion box design steering crown with pressed in tubes, a one piece billet brake arch and extra thick drop-outs. The WB forks bootless design allows a considerable amount more slider/stanchion overlap than competitor forks which increases the fork steering accuracy. Fork travel has been chosen to offer the best performance possible for each fork's intended use. To ensure peak performance, proper installation and periodic maintenance is required. When riding on public land, please respect the rights of others and stay on established paths and trails. By riding responsibly, you are helping ensure the future of our sport.

FORK INSTALLATION

White Brothers forks feature a 1-1/8" threadless steer tube. If you have a threaded type fork on your bicycle, consult your dealer for the appropriate upgrade parts necessary to convert to a 1-1/8" threadless steer tube.

1. Remove your old fork from the bicycle. Measure the diameter and length of your old forks steerer tube to ensure that the White Brothers steerer tube is the correct diameter and sufficient length for the installation.

2. Remove the crown race from your old fork.
3. Press the crown race onto your new White Brothers fork. (see **Figure #1**)
4. Preassemble the headset by sliding the fork steerer tube through the bearings. Then install the headset upper race, headset spacer (optional), and stem onto the fork steerer tube. Adjust with optional spacers to your preferred height. (See **Figure #2**) Refer to the head set owner's manual if there are any questions about the pre-assembly.
5. Mark the steerer tube at the top of the stem. The steerer tube will now need to be cut to the correct length. Disassemble and cut 3mm (1/8") below the mark. Consult your dealer or mechanic if you don't have the proper tools to cut the steer tube.
6. The star fangled nut must now be installed into the steer tube. If you don't have the set tool, we recommend dealer installation of this part. (See **Figure #3**)
7. Clean and grease all headset bearings and races to prepare them for assembly.

Note: Replace the bearings if there is any sign of wear or corrosion.
8. Now loosely assemble the headset, stem and handle bars as done in step four.
9. Install the headset top cap into the star fangled nut. Tighten until there is no play in the steering. The fork should rotate freely in the head tube. Straighten the stem in relation to the front tire and tighten the pinch bolts on the stem. If there are any questions consult your dealer or mechanic.
10. Install your front brake and adjust according to the manufacture's instructions.
11. Adjust the quick release on the hub to clear the secondary catches on the drop-outs. Tighten the quick release after the axle is properly seated in the drop-out. Ensure that there is sufficient thread engagement (5 or more threads with the quick release in the lock position) due to the thicker White Brothers drop-outs. Install the front wheel per manufactures specifications.
12. Check to see that the brakes are adjusted and properly working. Make sure that the brake cable does not interfere with any part of the bike when the fork is compressed and released.

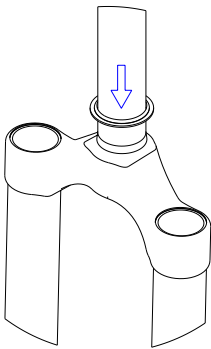

Figure #1

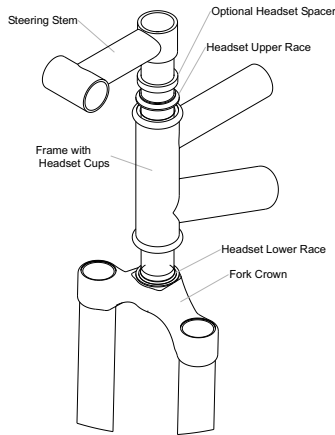

Figure #2

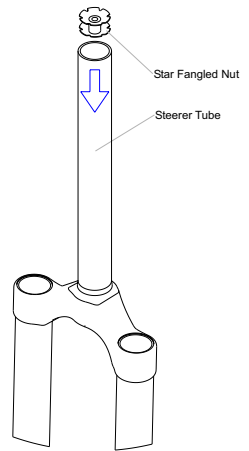

Figure #3

WARNING: All White Brothers 20mm forks are designed based on the IS disk brake standard. If your White Brothers fork has a 20mm through axle, it is critical to safety and function that you only use a disk brake properly designed for the 20mm IS disk brake standard. Simply spacing a non 20mm disk brake to work on the 20mm fork may result in insufficient thread engagement when attaching the brake. This can result in SERIOUS BODILY INJURY OR DEATH. ONLY USE DISK BRAKES PROPERLY DESIGNED FOR THE 20MM IS DISK BRAKE STANDARD.

WARNING: When installing the wheel or a new tire, check for minimum clearance. Measure from the highest point on the tire to the under side of the crown. There must be 1/8" or 3mm more clearance than the fork's travel to ensure adequate clearance in all riding conditions. Any less clearance can result in the tire hitting the crown resulting in serious injury or death.

TUNING

To get the most out of your White Brothers fork, it is important that you tune the fork to fit your weight, riding style and the terrain you ride.

INITIAL BREAK-IN PERIOD

Your new fork is designed to break-in over a period of 10 hours or more of riding. As all the parts bed into each other, the stiction (friction) of the fork decreases and the sensitivity increases. After the initial brake-in period, fine tuning the air pressure and damping adjustments may be beneficial to achieve the best possible performance.

TOOLS NEEDED:

- High pressure air pump
- 24 mm. socket with ratchet
- 4 mm. Allen wrench
- 6mm Allen wrench

AIR SPRING /IMV THRESHOLD DAMPER

Your new White Brothers fork is designed with air sprung support. The following guidelines for checking and adjusting your air pressure will enable you to enjoy maximum performance from your fork.

1. First, test ride the fork over easy terrain. If after riding the fork over varied terrain you decide that more tuning is necessary, continue to the next step.
2. The compression or spring of the fork can be changed two

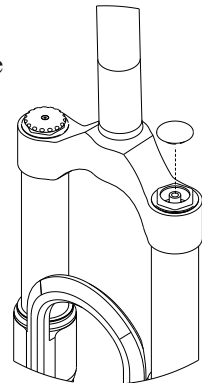
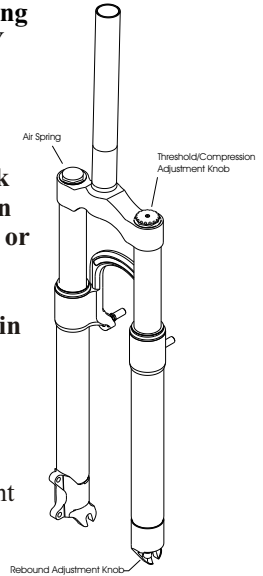

ways: 1) by changing air pressure and 2) adjusting the settings of the damper cartridge.

3. To change the air pressure remove the snap in dust cap (use a finger nail or small screw driver) so that the schrader valve stem is exposed (see Figure #4).
4. You will need a high pressure shock pump to inflate the fork. Start with the stock setting of 80 lbs. If the fork feels too soft or firm, fine tune the air pressure until the fork sag is approximately 15 to 25 percent of the total travel. A small air pressure change will make a large difference.
5. Test ride after each adjustment until the air pressure is at an adequate setting.
6. Compression adjustment for your body weight and riding style is done by means of the IMV knob at top of the right fork leg. There are thirty clicks of adjustment. The standard factory setting is sixteen clicks back (counter-clockwise) from full tight. Turning the knob clockwise slows down the responsiveness of the fork; turning it counter-clockwise makes the fork more active. Find the setting that limits unwanted movement ("bobbing") during climbing and sprinting but still allows the fork to step over bumps compliantly. Do not attempt to set the IMV adjustment by pushing on the fork with the bike stationary, since the anti-bob damping action is dynamic and can only be judged by riding the fork. Also, the damping can be expected to become somewhat firmer after the first few rapid compressions of the fork.
7. **Rebound adjustment** is done by turning the adjuster on the bottom of the right leg. There are 1-3/4 turns of adjustment. Start with the knob on the fastest setting. Push the fork down into the travel and then quickly lift the front wheel off the ground. Tighten the knob approximately 1/4 turn at a time until the wheel does not shudder when the fork extends. Proper rebound will allow the tire to track the ground over consecutive bumps. Rebound set too slow will cause the fork to pack-up (feel stiff over consecutive bumps) while rebound set too fast will cause the fork to top out harshly.

NOTE - It is not recommended that your IMV damper fork be stored upside-down. This may cause the oil to drain from the IMV damper system and result in a temporary loss of the IMV threshold. If the fork is stored upside-down, the IMV threshold should be able to be restored by pumping the fork several times to full bottom out or after a short period of normal riding.

MAINTENANCE

TOOLS NEEDED:

High pressure air pump
6-Millimeter Hex Key

Your White Brothers fork requires periodic maintenance to ensure peak performance and long life. Neglecting proper maintenance will reduce the fork's life. Internal build up of water and dirt or a lack of lubrication will cause excessive wear and void the warranty.

BEFORE EVERY RIDE: Visually inspect your fork for bent or broken parts, loss of oil, abnormal sounds or other indications of possible fork failure. Compress you

fork to verify proper function. Check all other bicycle components to ensure proper working order.

AFTER EVERY RIDE: Clean and dry the exterior of your fork. When cleaning the fork, do not direct the water spray at the seals. Visually inspect your fork for damage.

***EVERY 20 - 40 HOURS OF RIDING:** The damper leg is lubricated by damping oil and does not need relubrication until a general service is performed (see next section). Relubrication of the air spring leg should be done at least every 20 hours of riding if the forks is being used in very muddy or dusty conditions. If the fork appears to be relatively clean the period can be extended to as long as 40 hours. To relubricate the air spring leg of the fork, put the bike in a workstand and remove the front wheel (if a workstand is not available, prop the bike securely). Place a tray or other receptacle under the fork to catch oil drips. Loosen the compression screw on the bottom of the air spring leg with a 6 mm hex key until the screw protrudes 5 - 10 mm. Reduce the air pressure in the spring leg to approximately 40 psi. While holding the lower leg, use a mallet to firmly tap the screw upward to unseat the compression rod inside the leg. Remove the screw. (Note: Do not pull on the lower legs of the fork with the screw removed or the fork may hyper-extend and the key on the IMV adjustment knob may become detached from the damper.) Depress the core of the schrader valve to release the remaining air from the leg. Allow the fork to sit for several minutes so that old oil can drip out of the leg. Rotate the fork in the workstand until it is upside-down, or prop the bike in an upside-down position. Pour approximately 15cc of fork oil (any SAE rating from 4 to 20 wt.) into the compression screw hole. With the fork still upside-down, repressurize the air spring leg with a shock pump. Reinstall the screw in the leg and hand tighten with moderate force. (Note: The lightweight aluminum screw can break if it is overtightened.) If old oil in the fork is heavily contaminated with dirt or sand, 60 - 90 cc of oil can be poured into the fork and then allowed to drain overnight to clean the inside of the leg before relubrication. Always dispose of old or dirty oil responsibly.

***EVERY 100 HOURS OF RIDING:** Complete service should include removing the lower fork legs cleaning and re-greasing all shafts, bushings and seals. Check top cap assembly's, damper cartridge, stanchion plug, brake post bolts and shaft bolts for proper torque. At this time, the fork should be carefully inspected for wear and damage before reassembly. Contact White Brothers for replacement parts and service. We recommend that this service be performed by a certified White Brothers service center or by the factory.

***White Brothers recommends that you consult with a qualified technician before performing major service.**

FORK DISASSEMBLY AND GENERAL SERVICE

General fork service, including inspection and possible replacement of seals and bushings, is best performed by an experienced bicycle mechanic with a full assortment of tools for the purpose. Excessive looseness, severe stiction or leakage of oil or air are indications that the fork may need general servicing. Seasonal service is advisable if the fork is being subjected to very heavy use, such as that associated with cross country racing. Factory service is available for all models of forks; call the number listed on the back of this owner's manual for details.

TROUBLE SHOOTING

Loss of Air Pressure (In Excess of Normal Seepage):

Inflate the fork to 100 psi and spray a mixture of soap and water on the air cap with the dust cap removed. Check for any slow bubbling.

1. Make sure that the air cap is tight in the stanchion and that the schrader valve is tight in the air cap. Note: excessive tightness is not necessary for the air seals and may damage parts.
2. Check the valve core for bubbles. Slow bubble formation at the top of the schrader valve (one bubble every 30-60 minutes) is normal, more rapid bubbling indicates a loose or defective valve core. Tighten the valve core moderately with a valve core wrench. If tightening does not stop the leak, replace the valve core.
3. Spray the wiper on the air side leg with soapy water and check for bubbles. Bubbling at the wiper when the fork is at rest indicates a worn or damaged piston o-ring. If no leak can be seen after one minute, let the fork sit at high pressure overnight, then re-check pressure. If pressure drops significantly, the cause is probably a worn or damaged piston o-ring even though bubbling at the wiper may not be visible. The piston o-ring is easy to replace and is available through your local dealer or from White Brothers.

Fork Feels Sticky:

This is usually caused by:

1. A lack of lubrication. Clean and lubricate the fork as outlined in the maintenance section.
2. Contamination inside the fork. Clean and lubricate the fork as outlined in the maintenance section.
3. Fork is not sufficiently broken in. Contact White Brothers for further technical information.

The Fork Bottoms Too Easily:

1. Incorrect air pressure. Add air pressure as outlined in the tuning section.
2. Insufficient compression damping. Add compression damping by turning the IMV adjuster on the top of the right leg clock-wise.

The Fork Doesn't Use Full Travel:

1. Incorrect air pressure. Remove air pressure as outlined in the tuning section.
2. Excessive compression damping. Reduce the compression damping by turning the IMV adjuster on the top of the right leg counter clock-wise.

Loss of IMV Threshold:

1. If the fork was stored upside-down, the oil may have drained from the IMV damper system resulting in a temporary loss of the IMV threshold. The IMV threshold can be restored by pumping the fork several times or after a short period of normal riding.
2. Damper may need servicing. Contact White Brothers for technical information.

MAGIC 100 EXPLODED VIEW

Exploded Views

The following is an illustration and parts table which gives you the exploded view of each of our forks. The parts table lists the part numbers for each individual part in the fork. Reference these numbers when ordering replacement parts. See your local dealer to order the parts you require.

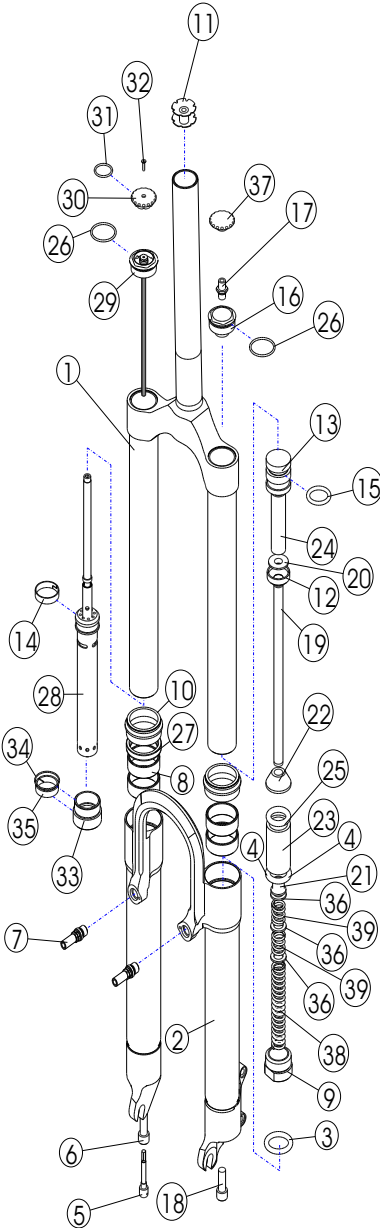

ITEM NO.	QTY.	PART NO.	DESCRIPTION
1	1	P1139-1	Upper Fork Assembly
2	1	100197,100199	Lower Fork Assembly
3	1	100009	Bottom Out O-Ring
4	1	ZTA-ORING-314	O-Ring
5	1	100200	Rebound Adjuster Knob
6	1	100063	Compression Screw, Hollow
7	2	97-3668	Brake Stud
8	4	97-986	DU Bushing
9	1	100235	Air Stanchion Plug
10	2	97-1351	Wiper
11	1	97-9301	Star Nut
12	1	100292	Top Out Stop
13	1	100572	Air Piston
14	2	P3000	Piston Band
15	1	100262	Air Piston O-Ring
16	1	100060	Air Leg Cap
17	1	100054	Schrader Valve
18	1	100063S	Compression Screw, Solid
19	1	100169	Compression Rod
20	1	P4600	Conical Nut
21	1	100576	Top Out Bumper Guide
22	1	97-3342	Top Out Bumper
23	1	100577	Top Out Spacer
24	1	100596	Piston Peg
25	1	F-2402	O-Ring
26	2	101271	O-Ring (Alt 100162)
27	1	P3060	Oil Seal
28	1	101390	IMV Damper 100
29	1	Cap Assbly	Damper Leg Cap Assembly
30	1	101276	Compression Knob
31	1	100036	Compression Knob O-Ring
32	1	100195	Compression Knob Screw
33	1	101273	Damper Stanchion Plug
34	1	101285	Stanchion Plug O-Ring
35	1	101405	Stanchion Plug Seal
36	3	P3310-1	Negative Spring Shim
37	1	101276-1	Schrader Valve Cap
38	1	100662	Negative Spring
39	2	100016	Auxiliary Negative Spring

MAGIC 29-100 EXPLODED VIEW

Exploded Views

The following is an illustration and parts table which gives you the exploded view of each of our forks. The parts table lists the part numbers for each individual part in the fork. Reference these numbers when ordering replacement parts. See your local dealer to order the parts you require.

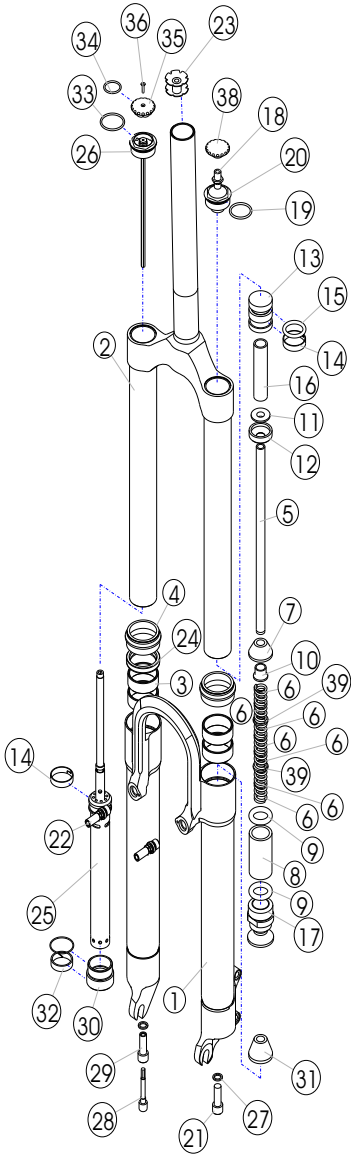

ITEM NO.	QTY.	PART NO.	DESCRIPTION
1	1	100226	Lower Fork Assembly
2	1	P1139-1	Upper Fork Assembly
3	4	97-986	DU Bushing
4	2	97-1351	Wiper
5	1	100601	Compression Rod
6	7	100016	Negative Spring
7	1	97-3342	Top Out Bumper
8	1	100577	Top Out Spacer
9	2	F-2402	O-Ring
10	1	100576	Top Out Bumper Guide
11	1	P4600	Conical Nut
12	1	P2504	Top Out Stop
13	1	100572	Air Piston
14	2	P3000	Piston Band
15	1	100262	Air Piston O-Ring
16	1	100596	Piston Peg
17	1	100227	Air Stanchion Plug
18	1	100054	Schrader Valve
19	1	100162	O-Ring (Alt 101271)
20	1	100060	Air Leg Cap
21	1	100063S	Compression Screw, Solid
22	2	97-3668	Brake Stud
23	1	97-9301	Star Nut
24	1	P3060	Oil Seal
25	1	101388	IMV Damper 29-80/100
26	1	Cap Assbly	Damper Leg Cap Assembly
27	2	101245	Compression Washer
28	1	100200	Rebound Adjuster Knob
29	1	100063	Compression Screw, Hollow
30	1	101273	Damper Stanchion Plug
31	1	P3290	Bottom Out Bumper
32	1	101405	Stanchion Plug Seal
33	1	101271	Damper Leg Cap O-ring
34	1	100036	Compression Knob O-ring
35	1	101276	Compression Knob
36	1	100195	Compression Knob Screw
37	1	101285	Stanchion Plug O-ring
38	1	101276-1	Schrader Valve Cap
39	2	P3310-1	Negative Spring Shim

WARRANTY CLAIMS

White Brothers forks are the highest quality and as such are warranted to be free from defects in materials and workmanship for a period of one year from the date of purchase for the original purchaser. On receipt of the fork, if it is found to be defective, White Brothers will determine replacement or repair of the fork. This warranty is the sole and exclusive remedy. White Brothers shall not be liable for any indirect, special or consequential damages. Warranty does not apply to any product that has been installed improperly or adjusted using methods not outlined in this manual. Warranty also does not cover forks that have been misused, or forks that have missing/altered serial numbers (located on the back of the right fork stanchion). The fork is not warranted against damage in the appearance of the fork or for modifications not outlined in this manual. This warranty does not cover breakage, bending, or damage that may result from crashes, falls or abuse. Normal wear (i.e. seals, bushings, sliders finish, etc) and tear and damage caused by lack of proper maintenance is not included. ***The warranty registration card must be filled out and returned within 30 days of purchase to activate and validate this warranty.** A copy of the proof of purchase must be included with all warranties. Customers in the US please contact your White Brothers or your dealer for a Return Authorization Number (RA#) before returning the forks. All forks returned for inspection must be sent freight paid to: White Brothers Cycling, 580 N. Westgate Dr., Grand Junction, CO 81505, USA.

OWNERS NAME:

ADDRESS:

PHONE:

PURCHASE DATE:

MAINTENANCE LOG

<u>Date</u>	<u>Service Performed</u>

MAINTENANCE LOG

Date

Service Performed

<u>Date</u>	<u>Service Performed</u>



A DIVISION OF



MOUNTAIN RACING PRODUCTS, INC
580 N. WESTGATE DR.
GRAND JUNCTION, CO 81505 USA
1.970.241.3518
WWW.WHITEBROTHERSCYCLING.COM